



Measuring Cyclist Level of Service on Narrow Pathways

Situation

Two bridges:

- Narrow sidewalks — cyclists and pedestrians share
- Low usage — 50 to 100 cyclists/day on each bridge

Want to widen sidewalks

- Improve safety
- Encourage cycling



Situation



Situation



Situation



Situation



Problem

How to measure the benefits
of widening?

Need a means of quantifying
change



Problem

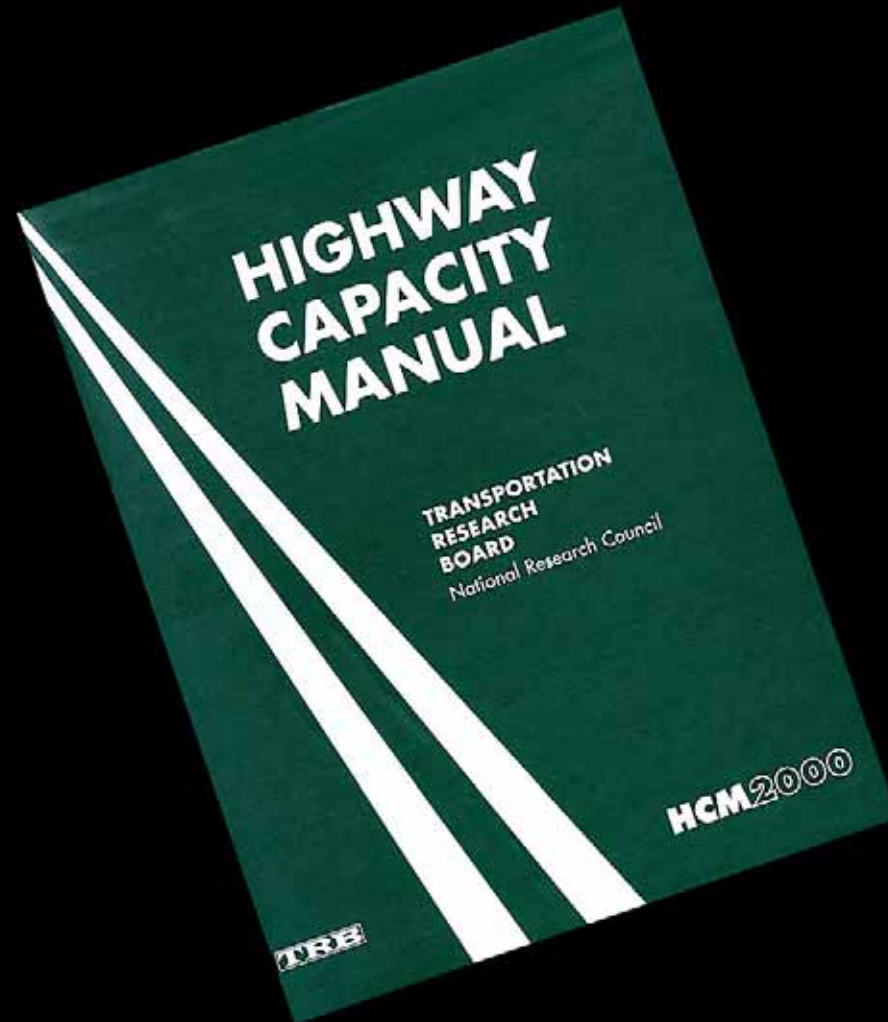

Problem

Highway Capacity Manual:

- 3.0 m (10 foot) wide pathway
- 2.4 m (8 foot) wide pathway

Pattullo Bridge:

- 1.8 m (6 feet)

Knight Street Bridge:

- 1.3 m (4 ¼ feet)



Theory

Highway Capacity Manual:

- ✘ Bicycle LOS based on concept of lanes and passing manoeuvres
- ✓ Automobile LOS based on concept of delay
- ✓ Delay equates to additional travel time or reduced average speed



Theory

What causes delay?

- Encounters with other users:
 - Same direction cyclists
 - Opposite direction cyclists
 - Pedestrians
- Encounters with obstructions



Theory

Calculate delay:

- Estimate number of encounters
- Estimate time per encounter
- Calculate total delay
- Calculate average travel speed



Theory



Level of Service	km/h	mph
A	> 22	> 14
B	15–22	9–14
C	11–15	7–9
D	8–11	5–7
E	7–8	4.5–5
F	< 7	< 4.5

Theory

Calculations:

- Determine number of cyclists and pedestrians per hour
- HCM equations: encounters/hour
(Equations 19-5, 19-6 and 19-7)
- Divide by crossing time = average encounters/crossing
- Calculate total delay = events x delay/event
- Average speed = distance \div (free-flow crossing time + delay)



Theory



Width	Passing Speed	Delay
1.0–1.2 m	0	14.8 s
1.2–1.4 m	5 km/h	8.1 s
1.4–1.6 m	10 km/h	3.7 s
1.6–1.8 m	14 km/h	1.8 s
1.8–2.0 m	19 km/h	0.7 s
> 2.0 m	24 km/h	0

Results

Existing

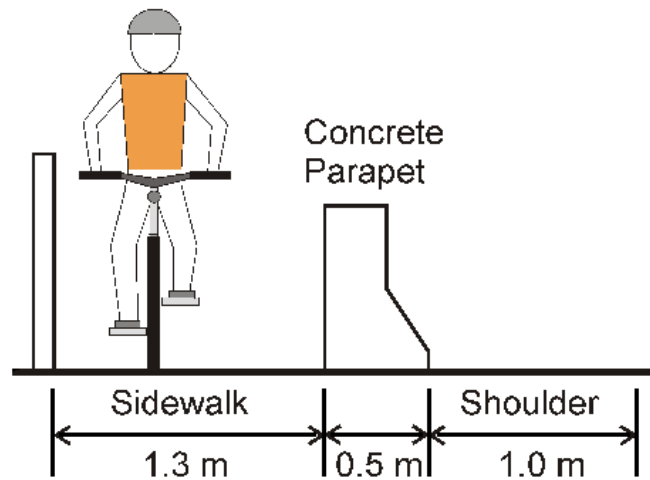

Proposed

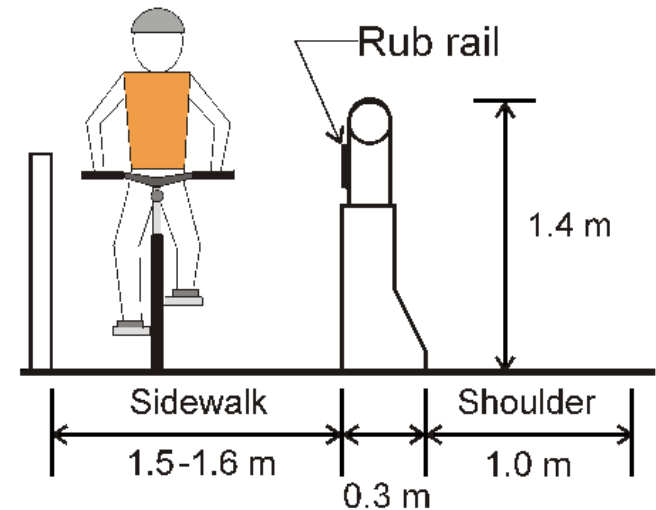

Results



Existing

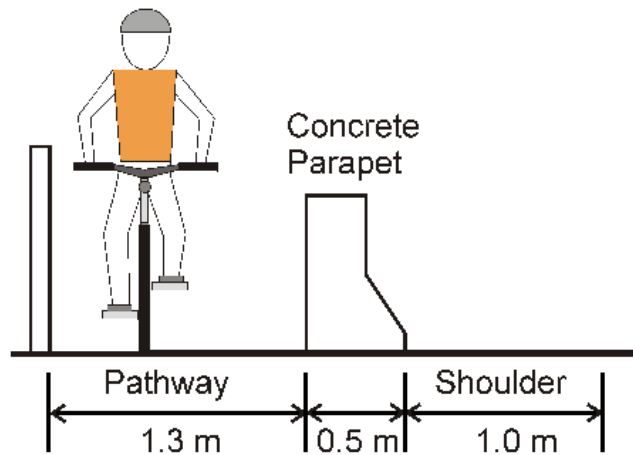

Proposed

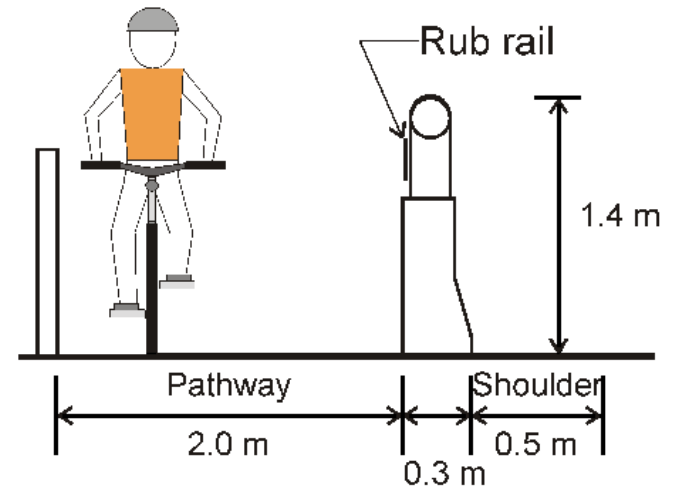

Results

Knight Street Bridge

Width	Hourly Volume	Average Speed	LOS
1.3 m	10	22.0 km/h	B
1.6 m	10	23.5 km/h	A
2.0 m	10	24.0 km/h	A
1.3 m	30	18.8 km/h	B
1.6 m	30	22.6 km/h	A
2.0 m	30	24.0 km/h	A

Results

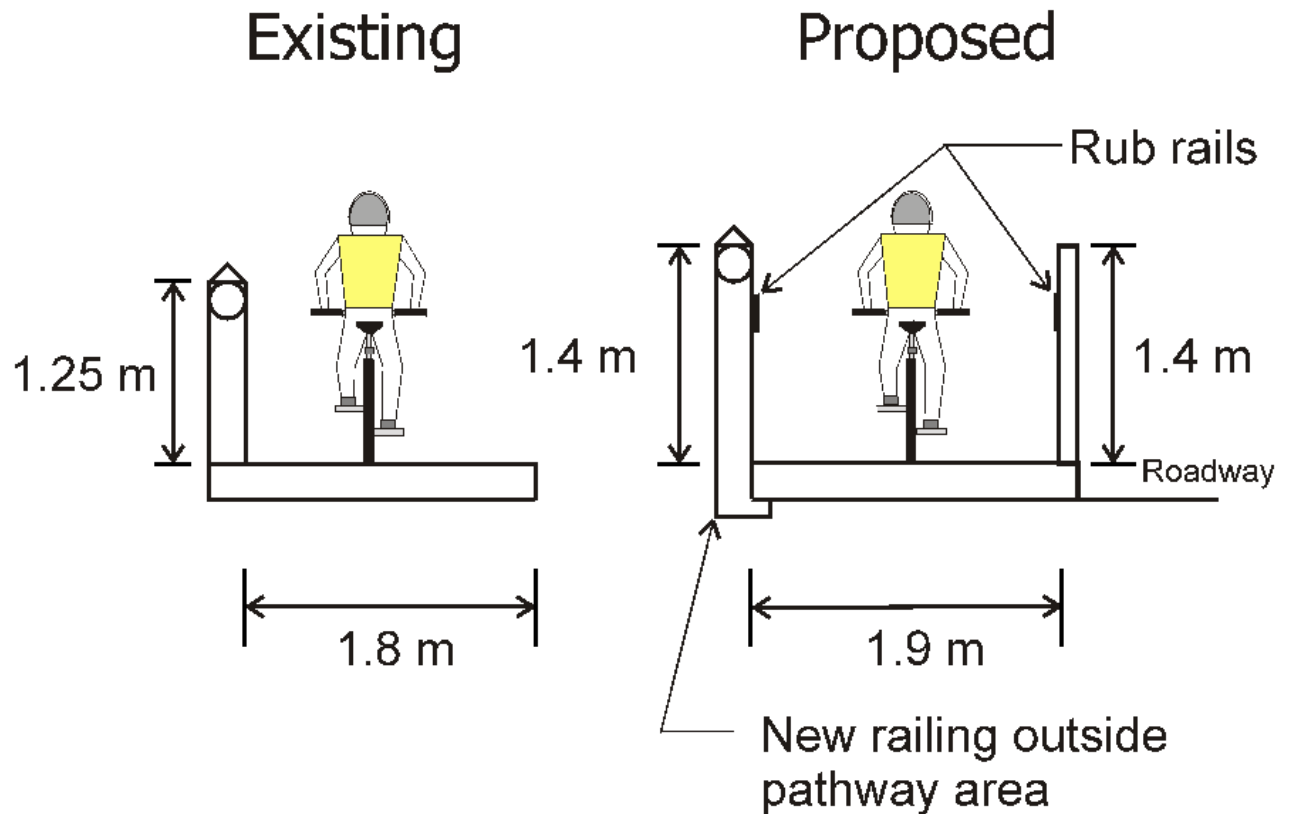

Results

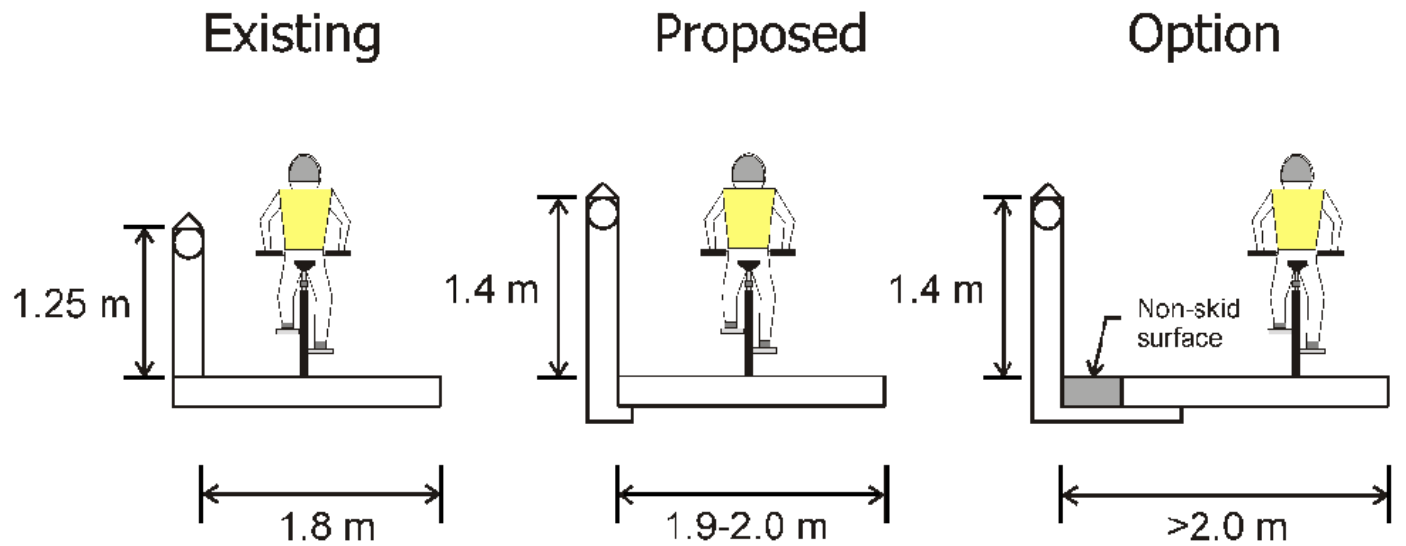

Results

Pattullo Bridge

Width	Hourly Volume	Average Speed	LOS
1.8 m	17	23.8 km/h	A
2.0 m	17	24.0 km/h	A
1.8 m	50	23.4 km/h	A
2.0 m	50	24.0 km/h	A



Improvements

Field observations of free-flow speeds

Adjust LOS average speed ranges:

- Narrow LOS B range — e.g. 19–22 km/h
- Adjust other LOS ranges accordingly

Different delays for different types of encounters

Field tests of delay at various widths





Measuring Cyclist Level of Service on Narrow Pathways

Richard Drdul, P.Eng., PTOE
www.drdul.com